

Herdecker Straße 26  
 58453 Witten (Germany)  
 T.+49 (0)2302/2027628 F.+49 (0)2302/61309  
[info@neo-studios.de](mailto:info@neo-studios.de)

Rodrigo Vairinhos  
 (Dipl. Industrial Designer)  
 T.+49 (0)2302/699775  
 M.+49 (0)176/20993904

Bernd Colditz  
 (Administrator)  
 T. +49 (0)2302/690982  
 M. +49 (0)176/20993788



# v.chair

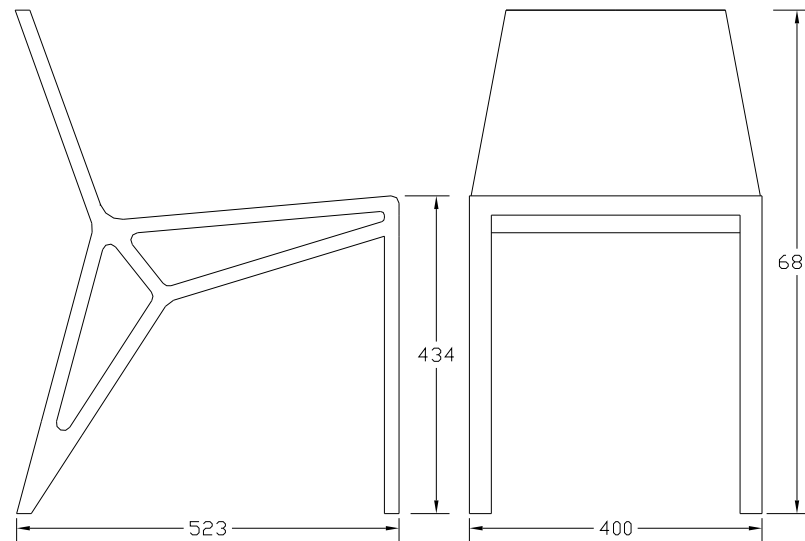

## Sample colors

White RAL 9016	Light-green RAL 6027	Light-gray RAL 7035
Black RAL 9017	Beech wood	Strawberry red RAL 3018
Greybeige RAL 1019	Yellowzinc RAL 1018	Pastel-orange RAL 2003
Light-blue RAL 5012	Blue-lilac RAL 4005	Erika-violet RAL 4003
Raspberryred RAL 3027	Braunbeige RAL 1011	Greenship RAL 6017
Maignruen RAL 6017	Light-green RAL 6019	Yellowgreen 6018

Design: Rodrigo Vairinhos, 2006  
 Material: Beech wood  
 Multifunctional chair for indoor/ exterior use.  
 Natural wood and various lacquer colors or epoxy membrane  
 Colors as suggested on the picture or by request.

Herdecker Straße 26  
58453 Witten (Germany)  
T. +49 (0)2302/2027628 F. +49 (0)2302/61309  
[info@neo-studios.de](mailto:info@neo-studios.de)

Rodrigo Vairinhos  
(Dipl. Industrial Designer)  
T. +49 (0)2302/699775  
M. +49 (0)176/20993904

Bernd Colditz  
(Administrator)  
T. +49 (0)2302/690982  
M. +49 (0)176/20993788



## v.chair

---

The V.chair is an equipment designed in order to be placed indoors or outdoors.

This product features a concept inspired on the bridge/tower traditional construction: a mesh of Vs, making its legs its characteristic and intriguing element as well, involving the project in an architectural and technological aura which lays in basic triangular shapes.

The production was also an important factor to have in mind, requesting a simple wood work technology, resulting on the connection of pre-fabricated elements: legs, bottom and back.

An example of its technical and aesthetic versatility is a special edition adapted to kids (between 3-6 y.o).

V.chair is an equipment of strong appearance, stability, comfort and lightness.

*Der V.Chair zeichnet ist für den Innen- und Außenbereich nutzbar. Die für den Stuhl charakteristischen Elemente sind die Stuhlbeine, die an eine Brücken- oder Turmkonstruktion erinnern. Sie geben dem Stuhl ein hohes Maß an Stabilität. Er besteht lediglich aus vier Elementen und ist dadurch leicht produzierbar. Der Stuhl ist in einer den Bedürfnissen von Kindern angepassten Version in Kindergärten- und Kindertagesstätten einsetzbar.*

*V.Chair ist ein Stuhl im ungewöhnlichen Design und zeichnet sich durch Leichtigkeit, Schlichtheit und Multifunktionalität aus.*

A cadeira “V.” foi um equipamento criado de forma a satisfazer não apenas as necessidades estéticas e funcionais, tão imprescindíveis ao usuário contemporâneo, como futuramente (ergonomia e multifuncionalidade), como igualmente as necessidades de produção.

O elemento característico da cadeira “V.” são as pernas que tomaram inspiração nas composições constructivistas das tradicionais pontes ou torres, uma malha em forma de Vs que dão estabilidade à construção.

Um facto importante é também a forma desta poder ser facilmente produzida, resultando da junção de apenas quatro peças ( pernas, tampo e costas).

Em adição, este equipamento apresenta uma forte aparência, estabilidade, leveza e positivismo!

A cor é de igual forma bastante importante num espectro escolhido de forma a provocar e inspirar o usuário.